

BOWERPOWER
the blog about nothing and everything

X-BASE CONSOLE TABLE



MATERIALS

- 3 - 2x6x8' (or 1-2x6x8' and 1-2x6x12')
- 5 - 2x2x8'
- Screws
- Wood Glue

TOOLS

- Tape Measure
- Pencil
- Speed Square
- Miter Saw
- Clamps
- Drill
- Pocket Hole Jig
- Safety Glasses
- Hearing Protection

CUT LIST

- 4 - 2x2 @ 34" (legs)
- 5 - 2x2 @ 13.5" (under table support and rails)
- 2 - 2x2 @ 55" (diagonals)
- 2 - 2x2 @ 45" (front/back apron)
- 2 - 2x2 @ 21 3/4" (under table support)
- 3 - 2x6 @ 50" (top)

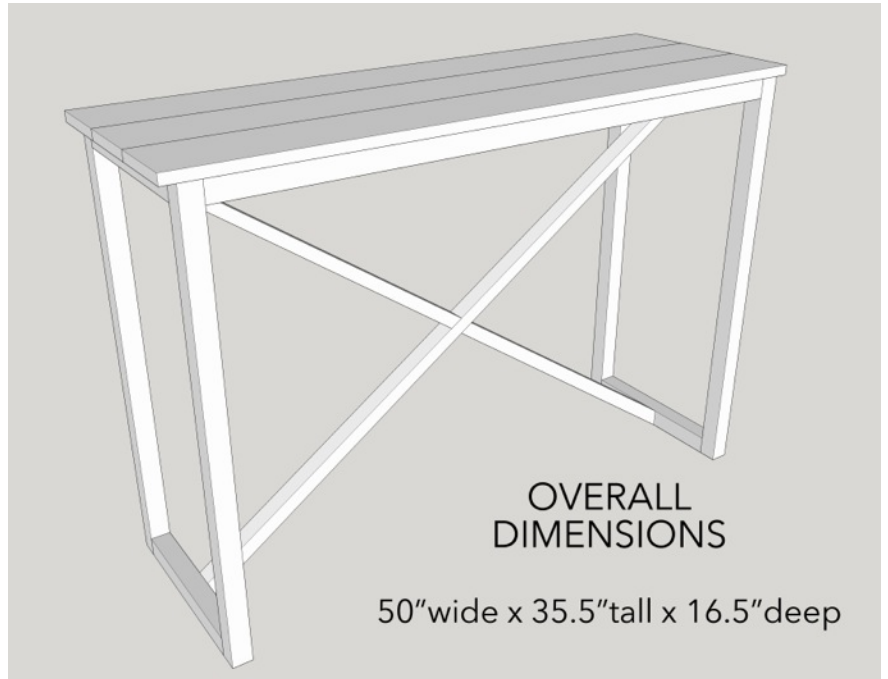

HOW TO CUT THE 2x2s

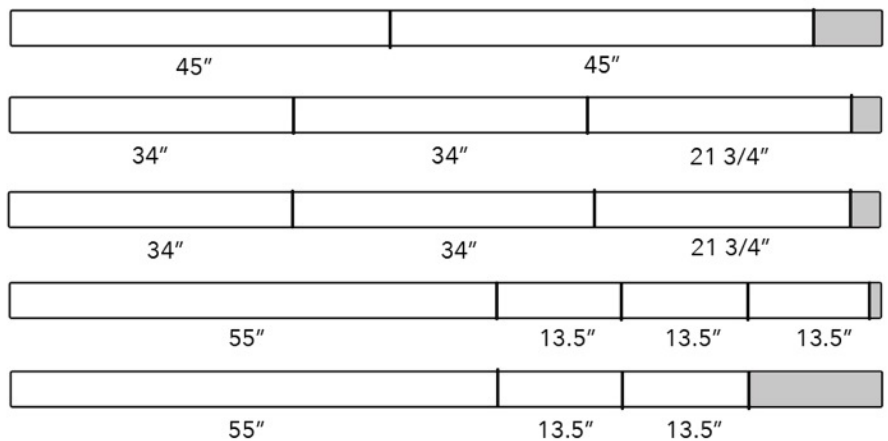

STEP 1 - BUILD THE LEGS

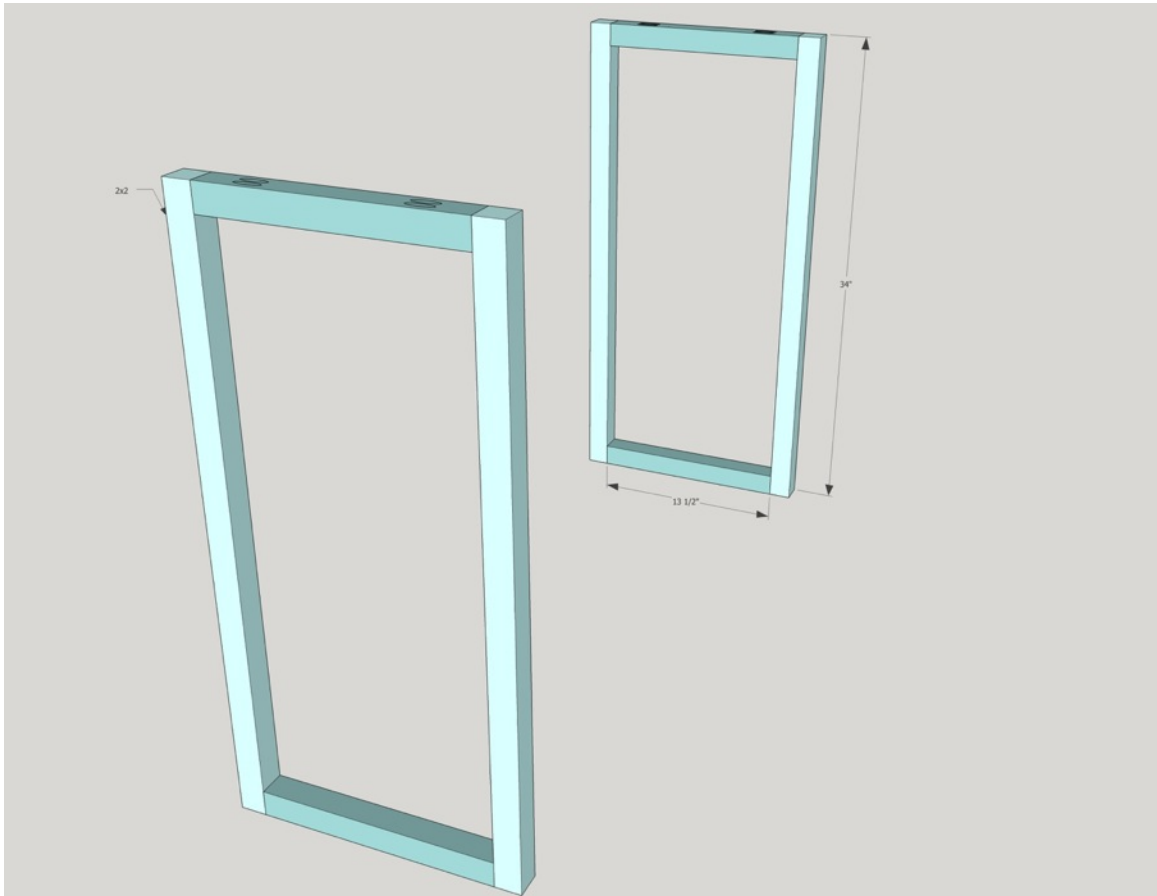

Drill 1 1/2" pocket holes into the 2x2 rails and attach them to the legs with 2 1/2" pocket hole screws and wood glue. Be sure that the pocket holes are facing the outside of each leg so they are hidden when the table is fully constructed.

STEP 2 - CONSTRUCT THE CARCASS

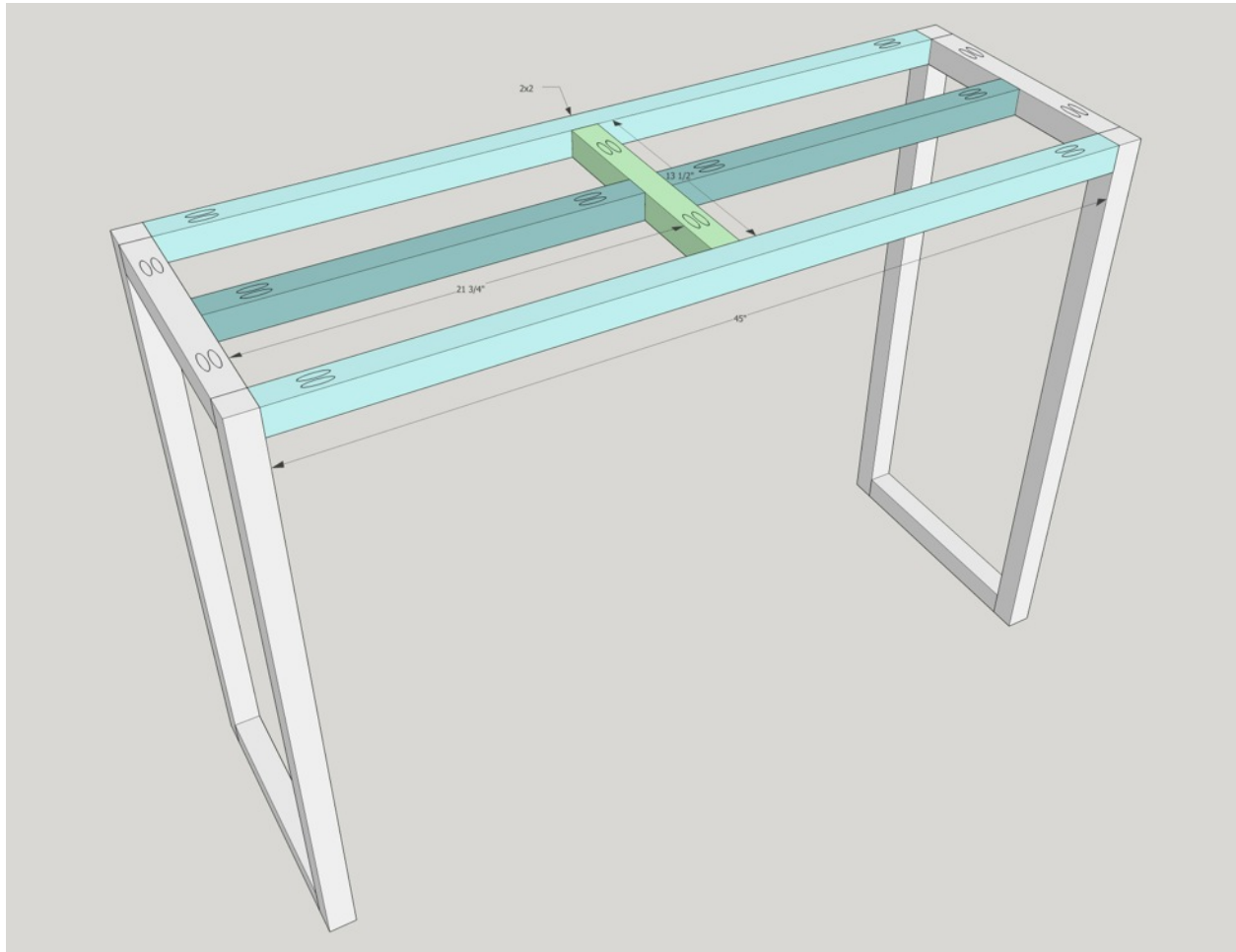

Construct the carcass. Drill 1 1/2" pocket holes into the 45" rails and attach to the legs with 2 1/2" pocket hole screws. Find the midpoint and attach the middle 2x2 board with 2 1/2" pocket hole screws and wood glue. Add the 21 3/4" pieces in the same way.

STEP 3 - CUT AND ATTACH THE X

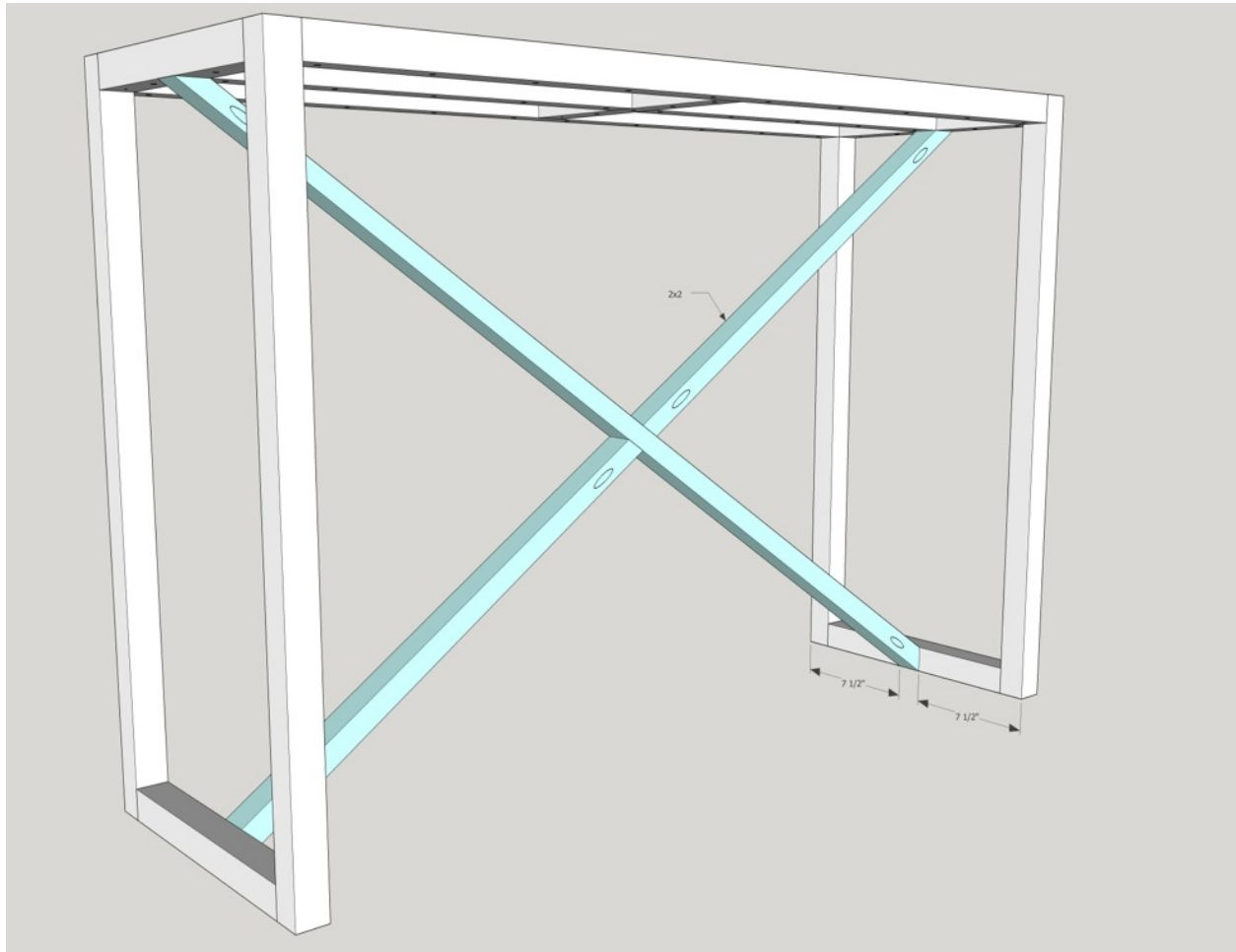

Cut and attach the X base. The long X piece is cut at 55° off square at the top end and mark and cut the bottom accordingly. The shorter X pieces are cut at a 55° angle at one end, while the other end is cut at a 35° angle. I recommend you measure your space and cut your boards accordingly to ensure the most precise fit. Note that the placement of the X base is centered on the table.

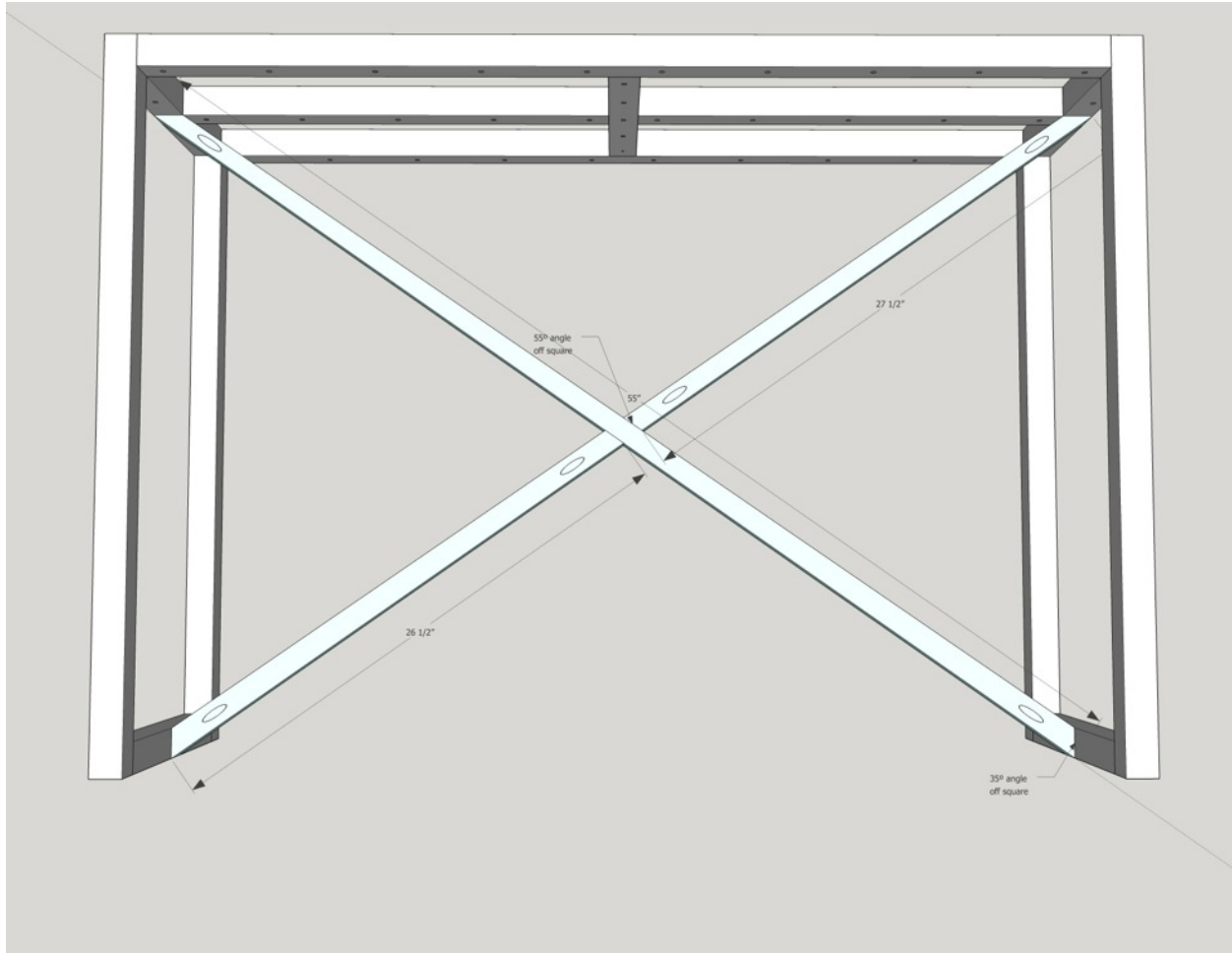

If your pocket screws do not feel secure, you can attach the top part of the X with a screw from beneath into the rails and the bottom part of the X with a screw into the rails.

STEP 4 - CONSTRUCT PLANKED TOP

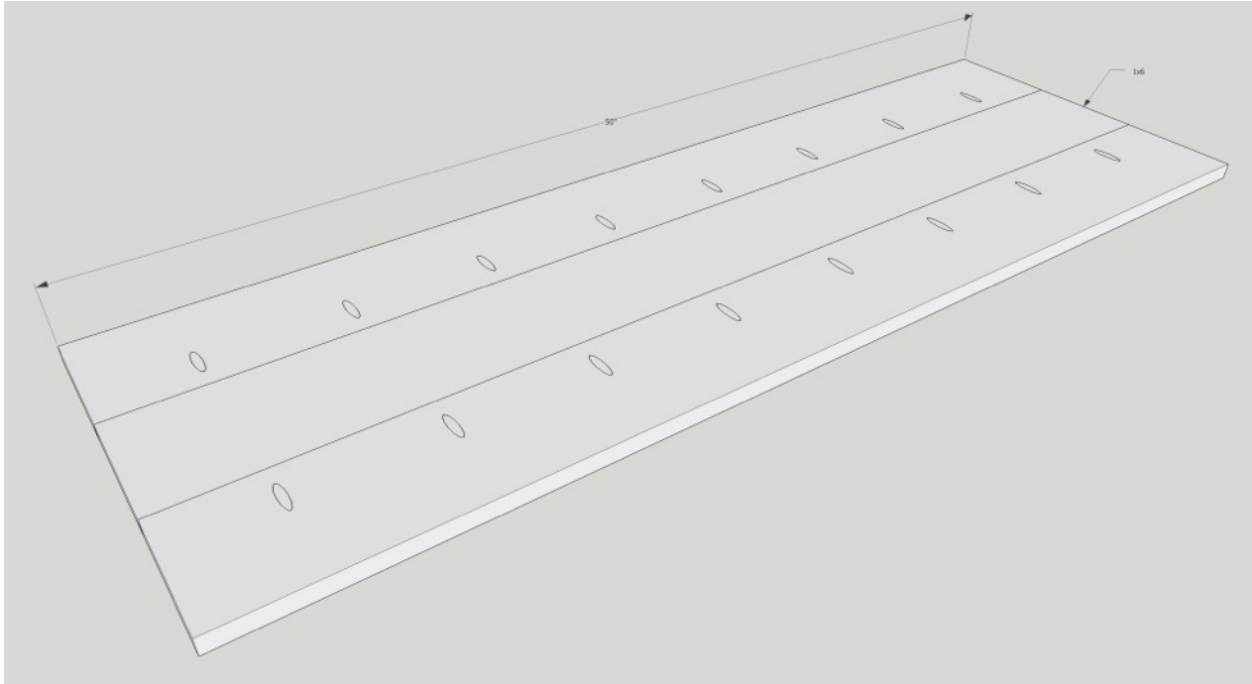

Construct the top. Drill $\frac{3}{4}$ " pocket holes into the edges of two of the 1x6 boards, plank them together and attach with 1 $\frac{1}{4}$ " pocket hole screws and wood glue.

STEP 5 - ATTACH PLANKED TOP

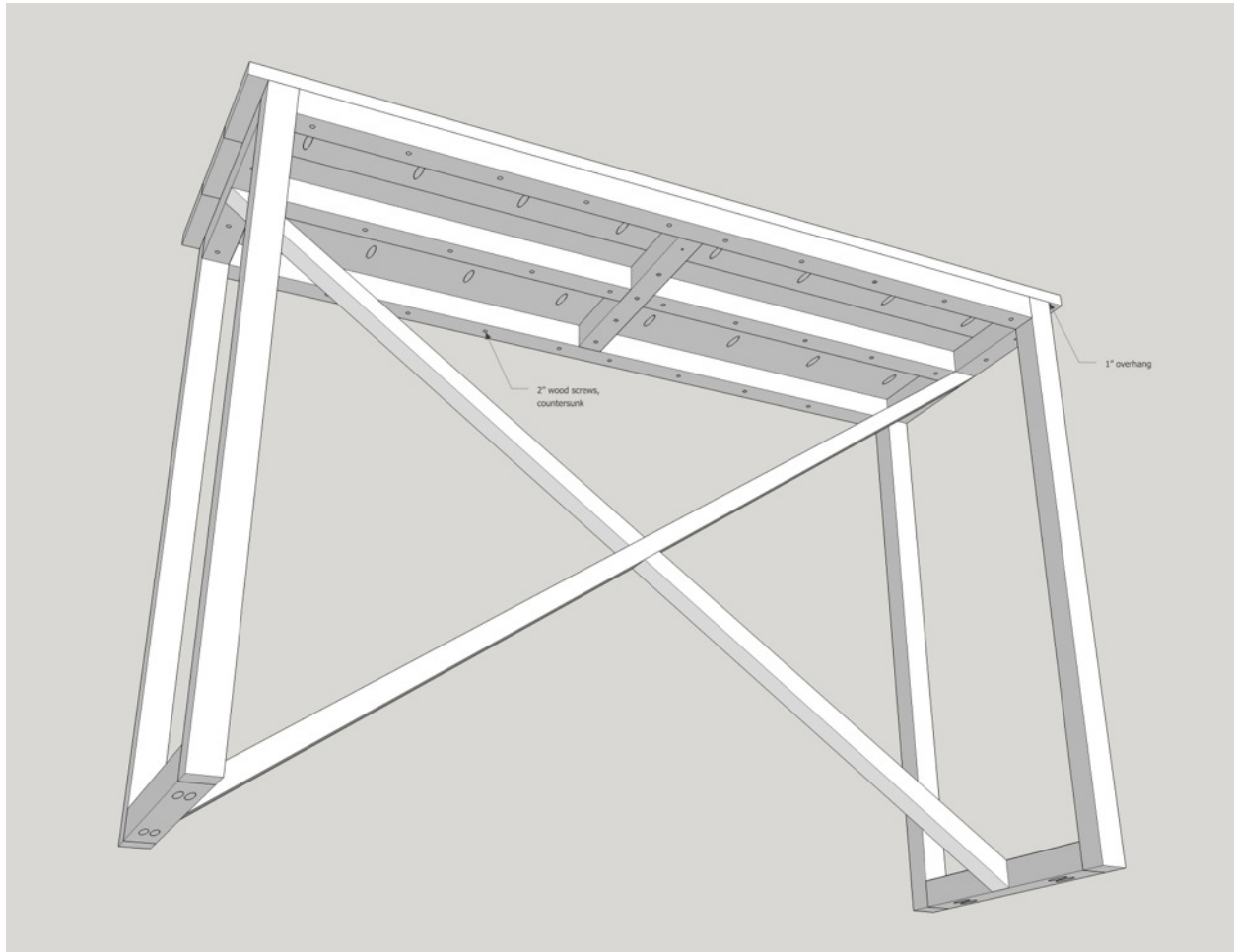

Pre-drill pilot holes from underneath (as shown) and attach the planked top with 2" wood screws. You may choose to countersink the pilot hole so that the screws sit flush with the wood. Note that there is a 1" overhang on both sides of the top.